

RHINO XL

AUTOMATION FOR SWING GATES

Installation and User manual

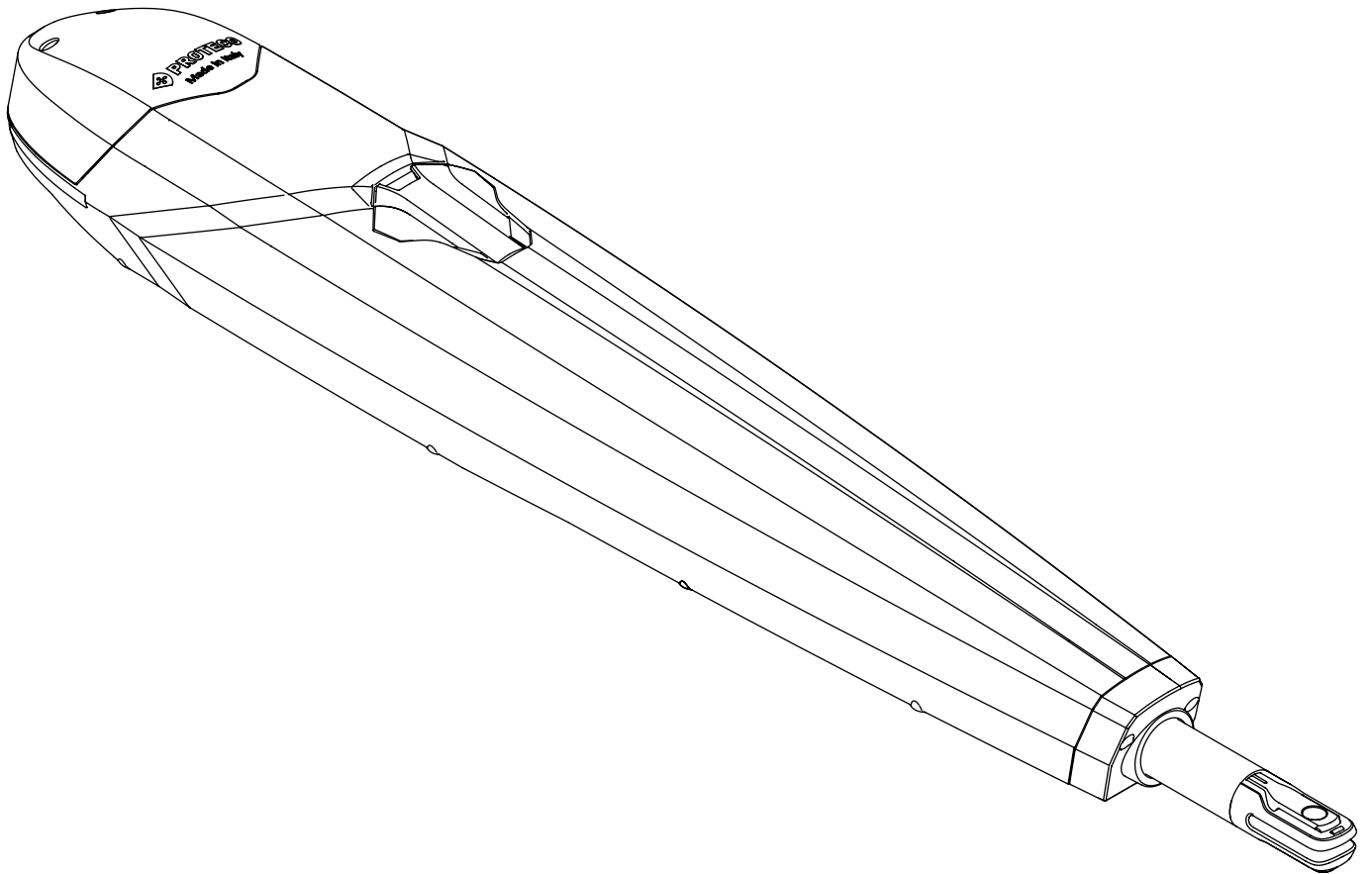

INDEX

1. WARNINGS	4
2. DESCRIPTION AND INTENDED USE	5
2.1 CONTENT	
2.2 ACCESSORIES	5
3. TECHNICAL FEATURES	5
3.1 MOTOR DIMENSIONS	5
4. ESTIMATED LIFE	6
4.1 USE LIMITATIONS	6
5. INSTALLATION	6
5.1 INTRODUCTION	6
5.2 PRELIMINARY CHECKS	6
5.3 INSTALLATION QUOTA	7
5.4 BRACKETS	7
5.5 UNLOCKING THE MOTOR	8
5.6 OPENING LIMIT SWITCH	8
5.7 INSTALLING THE OPERATOR	9
6. ELECTRICAL WIRINGS	10
6.1 POWER CABLE FEATURES CONNECTING THE CONTROL UNIT AND THE TERMINAL BLOCK ONBOARD THE MOTOR	10
7. END USER SECTION	12
7.1 WARNINGS	12
8. MAINTENANCE	13
9. WARRANTY	13
10. DISPOSAL	13
11. DECLARATION OF CONFORMITY	13

1. WARNINGS

This manual for MATRIX series contains important information concerning personal safety. An incorrect installation or an improper use may lead to severe injuries.

Read carefully and pay particular attention to the safety sections marked by the yellow triangle 

 Make sure the main power line is equipped with state of the art safety grounding system.

 The installation of automatic doors, gates and barriers must comply with the Machinery Directive 2006/42/CE and EN 12453 regulation, and performed by qualified personnel.

 Make sure the whole installation is protected by a power cut switch and against overcurrent.

Make sure the area is clear from flammable gases and/or electromagnetic interferences: it could lead to very dangerous injuries.

 Switch the power and batteries OFF before any operation.

After installation, packaging and waste materials (cardboard, plastic, metal parts etc.) must be kept away from children as they could be potentially harmful.

Use only original spare parts. Any alteration to the system is prohibited.

Proteco Srl will not respond in case of using additional and/or fake spares.

 Before commissioning the system, deliver the last pages of this manual to the user (section 7. END USER'S TIPS).

Proteco S.r.l. reserves the right to make changes to the product without notice

2. DESCRIPTION AND INTENDED USE

The Rhino is an electromechanical operator for swing gates, ideal for apartments or residential settings, with gates up to 5 meters in length. For gates larger than 2.5 meters, installing an electric lock is recommended.

2.1 CONTENT

Picture 1

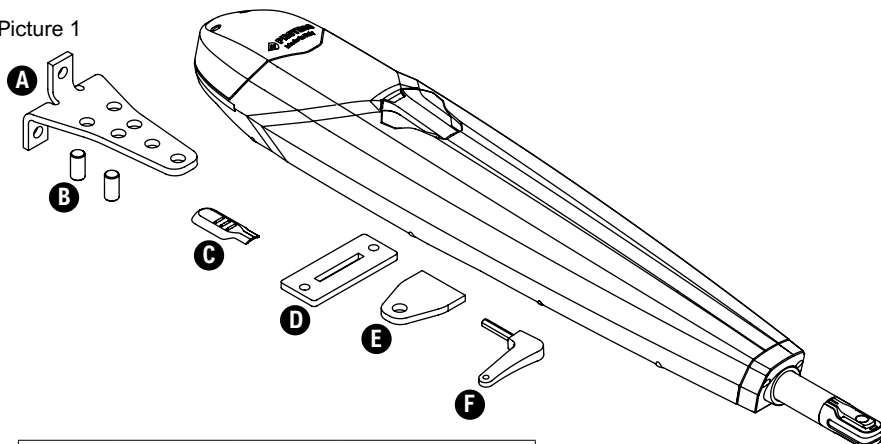

CONTENT DESCRIPTION			
ITEM	REFERENCE	UNITS	
MPIP10Z	A	1	PILLAR BRACKET
MPE1224	B	2	PIN
MTP28	C	1	FORK CAP
SPIA0870	D	1	BASE BRACKET
SPIA0770	E	1	GATE BRACKET
SCH0190	F	1	RELEASE KEY

2.2 OPTIONAL (sold separately)

Picture 2

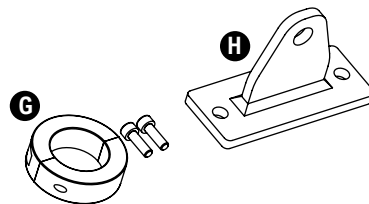

ACCESSORIES			
ITEM	REFERENCE	UNITS	
PFM01	G	1	Opening limit switch
SPIA0970	H	1	Welded gate bracket

3 TECHNICAL FEATURES

	RHINO XL 230V	RHINO XL 115V	RHINO XL 24V
Power supply	230V ~ 50Hz	115V ~ 60Hz	24V dc
Motor absorption	1.0 - 1.7 A	3.1 - 3.3 A	0.8 - 8 A
Rated power	300 W	300 W	80 W
Thermal cut off	150°C	150°C	--
Rated thrust	3800 N	3800 N	3200 N
IP rating	44	44	44
Revolutions	1400 rpm	1700 rpm	1600 rpm
Opening time	26"	22"	24" - 28"
Duty cycles	40%	40%	80%
Cycles per hour	18	18	32

3.1 MOTOR DIMENSIONS

Picture 3

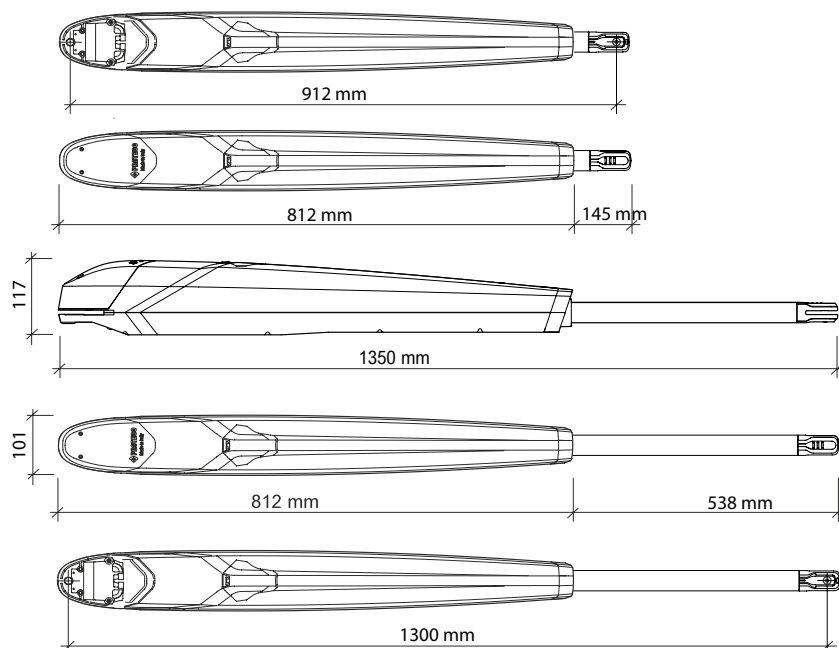

4. ESTIMATED LIFE

The life of the gearmotor may be affected by multiple waste factors. The life expectation can be calculated using the criteria outlined here below.

In order to get the waste rate add together all values in Table 1A that comply with the installation scenario and according to the accessories fitted

ATTENTION: If the wear index exceeds the value 10 it means that the installation conditions are not suitable for the chosen model.

Cross the graph line (Table 1B or 1C) with the wear index to find the maximum estimated duty cycles.

Duty cycles obtained may be compromised if the maintenance plan is not carefully respected.

Duty cycles are determined on the base of design analysis, project calculations and tests carried out at factory for a 90° opening.

Therefore the duty cycles achieved are a mere estimation.

The value obtained from the sum of the variants will be a number between 0 and 10 and will indicate the wear rate to be used on the graph to verify the durability of the product.

TABLE 1A

	RHINO XL 230V / 115V	RHINO XL 24V
Leaf max 1,5 m	1	1
Leaf max 2 m	1,5	1
Leaf max 2,5 m	2,5	1,5
Leaf max 3 m	3	2,5
Leaf max 3,5 m	3,5	—
Leaf Weight max 200 Kg	1,5	1
Leaf Weight 250 Kg	2	1,5
Leaf Weight 300 Kg	2,5	2,5
Leaf Weight 350 Kg	3	3
Strong wind	3	3
Panelled leaf	1,5	1,5
Outside temperature over 40° or lower 0°	1	1

4.1 USE LIMITATIONS

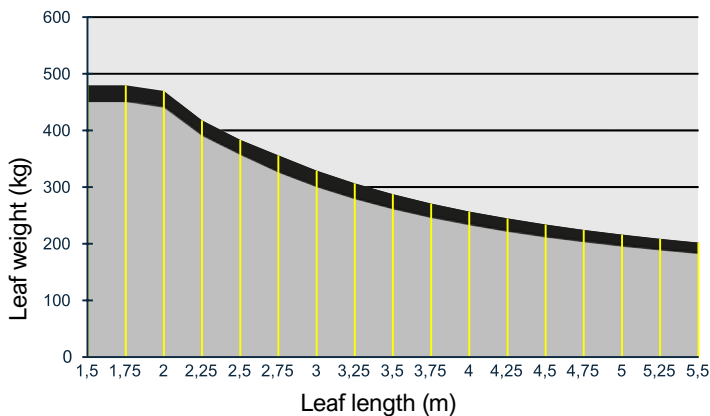

The table outlines the use limitations of RHINO, based on length and weight of the gate.

Black line values are referred to 230V/115V versions while the grey line values apply for the 24V.

TABLE 1B

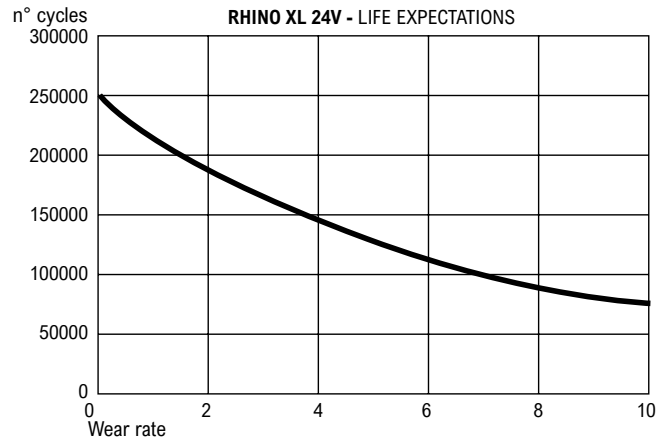
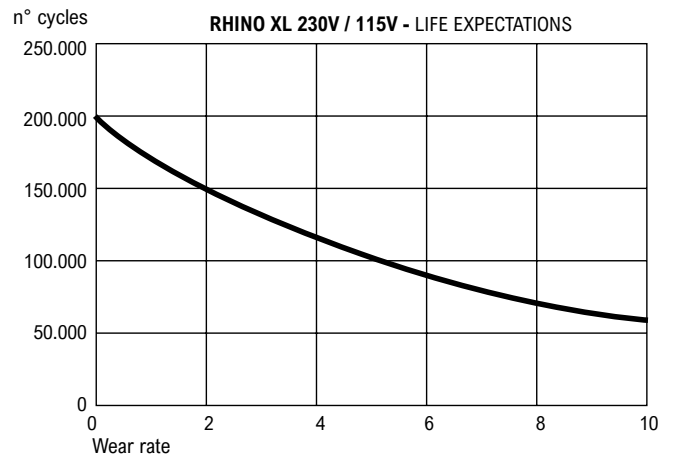

TABLE 1C



5. INSTALLATION

5.1 INTRODUCTION:

ATTENTION!



Any use other than that described and in environmental conditions different from those reported in this manual is to be considered improper and prohibited.

To correctly perform the installation follow in sequence all the steps indicated in this chapter

5.2 PRELIMINARY CHECKS

Before proceeding to installation, it is necessary to double check the good condition of every component and make sure the site is suitable for installation purposes.

- All components must be integral and suitable to use.
- Make sure the installation site complies with system's dimensions.
- Make sure weight, dimensions and gate features are suitable to the model you have chosen.
- Make sure the gate area is fitted with ground stops both in opening and closing.

- Make sure the gate is mechanically free of friction.
- Make sure the automation fixing area is compatible with the dimension of the brackets and there is sufficient space to carry out manual operation easily and safely.
- Make sure the automation positioning area is not subject to flooding;
- Make sure the electric circuit is connected to a state of the art safety grounding.
- Make sure the fixing surfaces of the photocells are flat and allow correct alignment between transmitter and receiver.

Picture 5

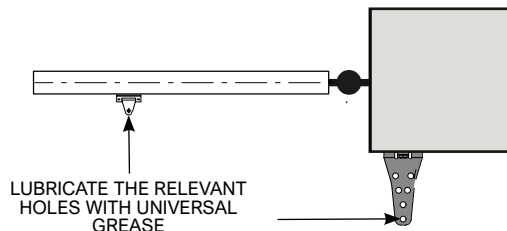

Place the brackets on the gate, ensuring compliance with the installation dimensions.

5.4 BRACKETS

PILLAR BRACKET

Picture 6

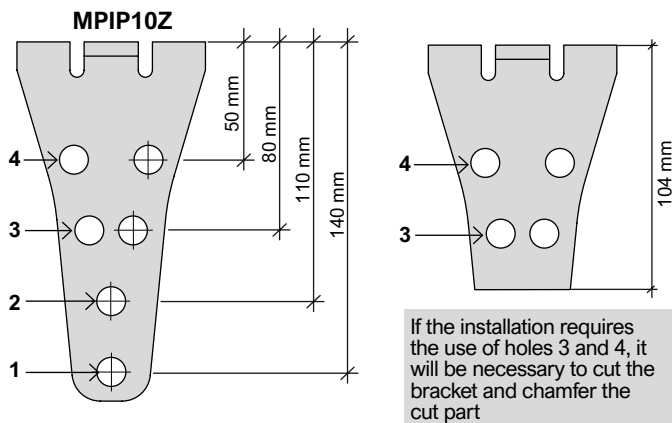

GATE BRACKET

The gate bracket can be used in different ways, depending on the installation requirements:

Picture 7

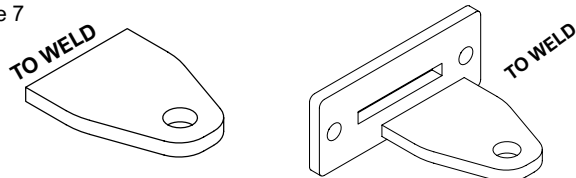

Weld the SPIA0770 bracket directly onto the gate.

Weld the SPIA0770 and SPIA0870 brackets, then fasten the assembly to the gate.



ATTENTION!

If precise measuring tools are not available for positioning the gate bracket, use the following procedure:

- Temporarily fix the pillar bracket to the pillar and anchor the motor.
- Unlock the actuator by following the instructions provided in paragraph 5.4 of the manual.
- Extend the stainless steel tube, maintaining a 2 cm gap from the maximum stroke.
- Insert the gate bracket into the actuator fork, secure it with the connection pin, and mark the position on the gate leaf.
- Perform an opening and closing cycle to verify the correct positioning of the brackets and proper operation of the actuator.
- Permanently secure the brackets to the pillar and the gate.

5.3 INSTALLATION QUOTA

Picture 4

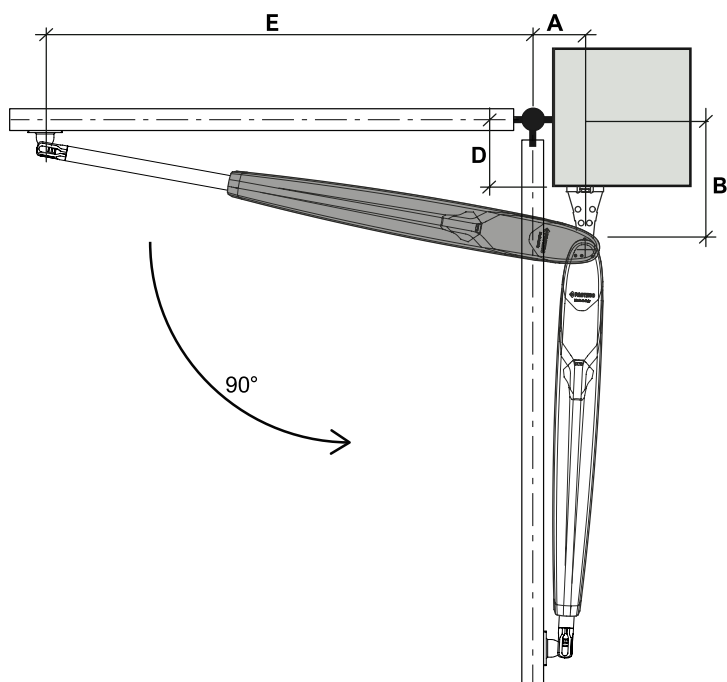

Opening 90°										
D	225	200	175	150	125	100	75	50	25	0
A	85	95	100	100	120	120	130	140	140	140
B	275	250	250	230	205	180	185	160	135	140
E	1200	1190	1180	1180	1170	1170	1160	1150	1150	1150
Pillar bracket hole	4	4	3	3	3	3	2	2	2	1
Bracket quota	50	80	80	80	80	80	110	110	110	140
Max opening angle	90	90	90	95	95	100	100	100	100	100

Opening 110°				
D	75	50	25	0
A	160	170	170	170
B	155	160	135	140
E	1130	1130	1130	1120
Pillar bracket hole	3	3	2	1
Bracket quota	80	80	110	140
Max opening angle	110	110	110	110

Opening 120°		
D	25	0
A	190	190
B	105	110
E	1110	1110
Pillar bracket hole	3	2
Bracket quota	80	110
Max opening angle	120	120

Values are expressed in mm.

5.5 UNLOCKING THE MOTOR

Lift and hold the plastic flap (Picture 8), plug the release key SCH0190 in the exagonal slot, rotate about 90° clockwise in order to unlock and viceversa to lock back.

Picture 8

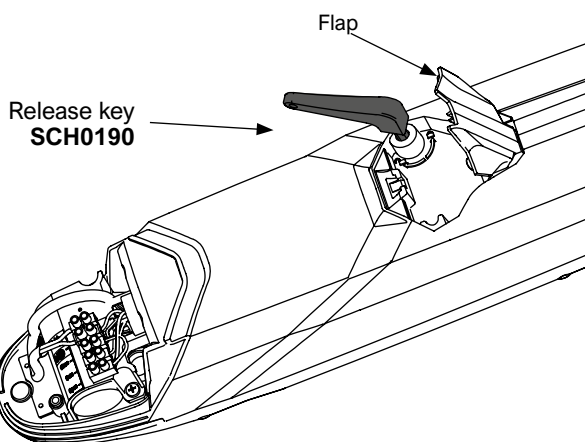

Picture 9

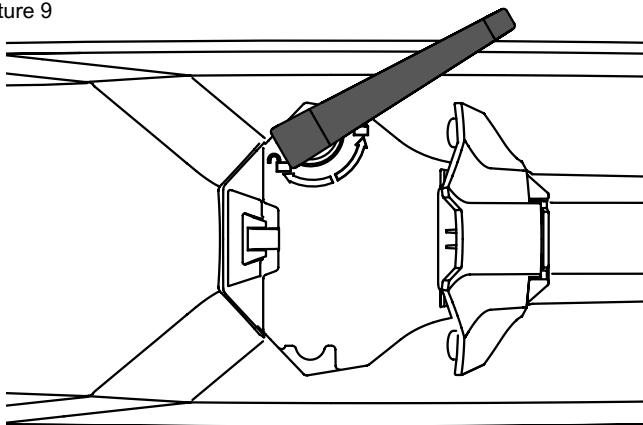

5.6 OPENING LIMIT SWITCH (OPTIONAL)



ATTENTION!

If the gate is not equipped with a mechanical stop, it is recommended to install an opening limit switch.

Use a 5 mm Allen key to adjust the limit switch.

Picture 10

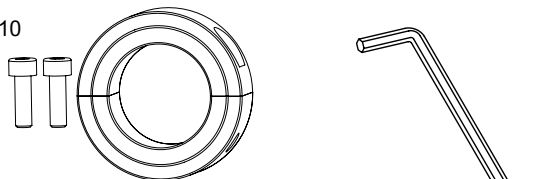

Picture 11

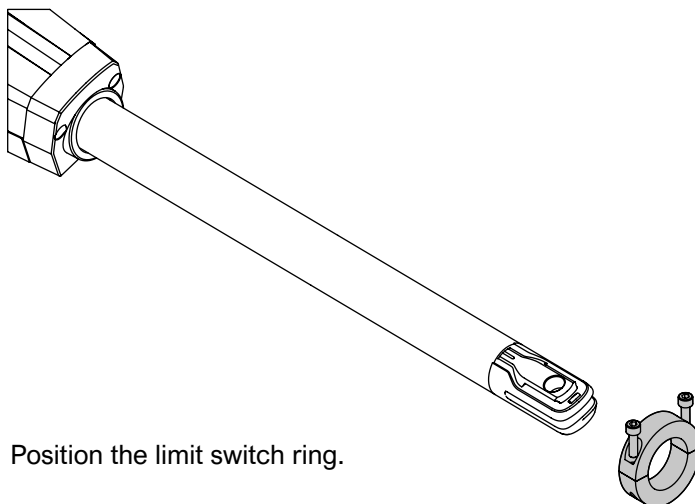

Picture 12

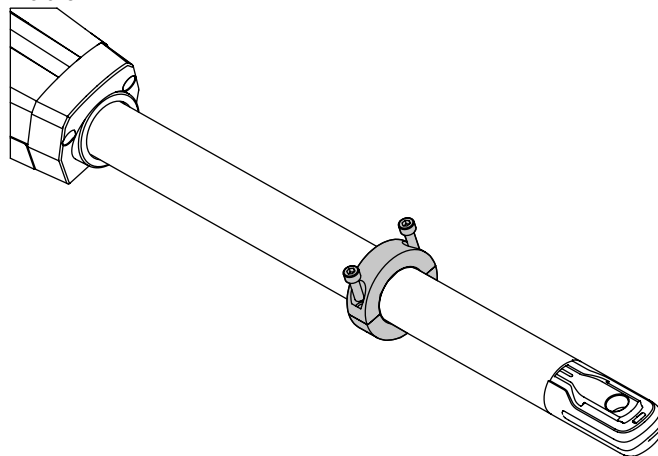

Gradually tighten both screws, alternating between them. For proper installation, it is recommended to tighten them evenly."

Picture 13

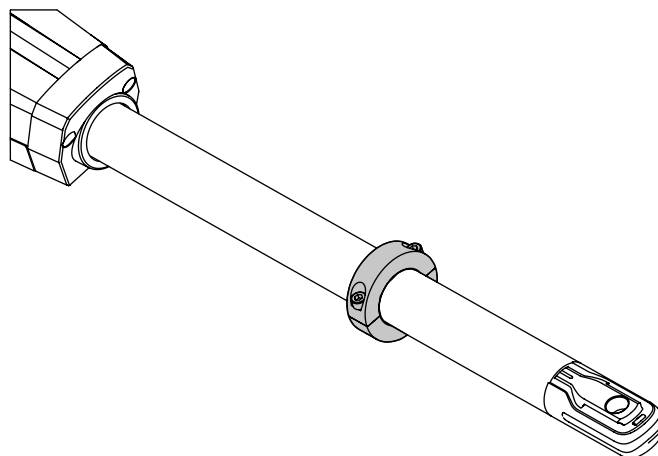

5.7 INSTALLING THE OPERATOR

ATTENTION:

“Before mounting the operator on the MPIP10Z bracket, check that the selected hole does not require the bracket to be cut. Keep a 3 mm Allen key, the two MPE1224 pins, and the SCH0190 release key at hand. (See paragraph 5.4)

Picture 14

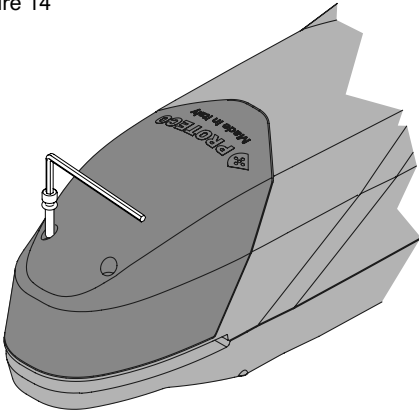

Remove the cover using a 3 mm Allen key.

Picture 15

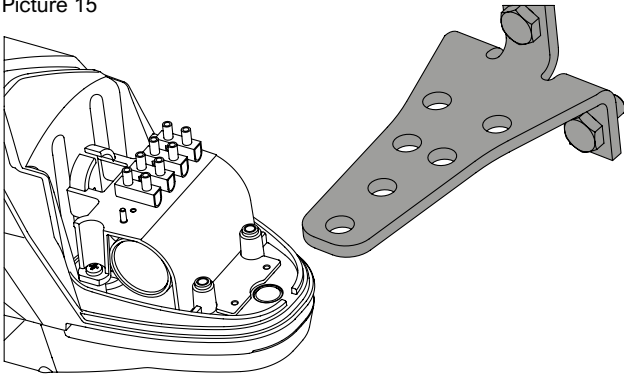

Position the automation near the bracket.

Picture 16

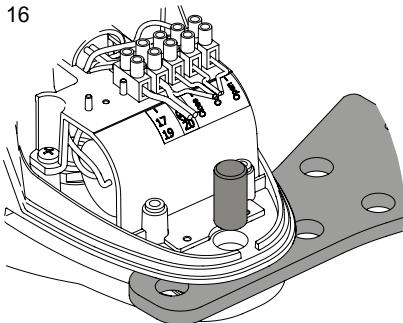

Position the actuator aligned with the selected hole.

Picture 17

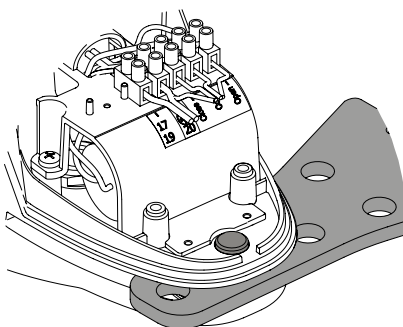

Insert the MPE1224 pin into the hole.

Picture 18

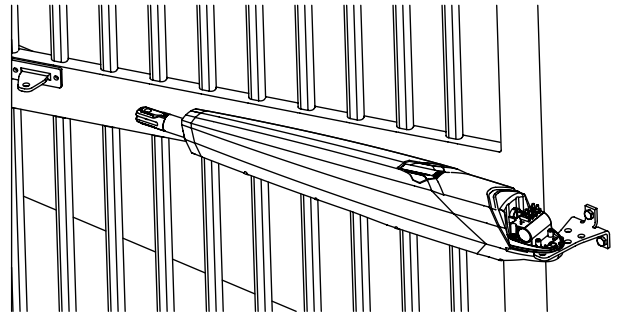

Unlock the automation and extend the stainless steel pipe.

Picture 19

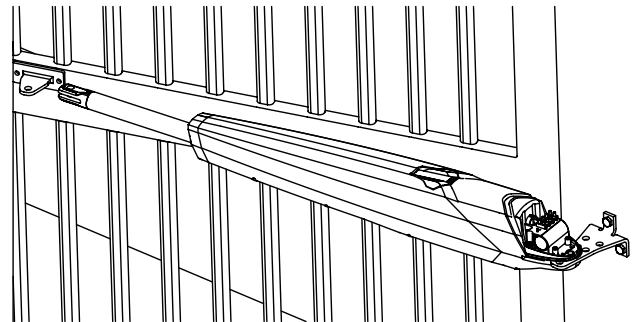

Bring the fork close to the gate bracket .

Picture 20

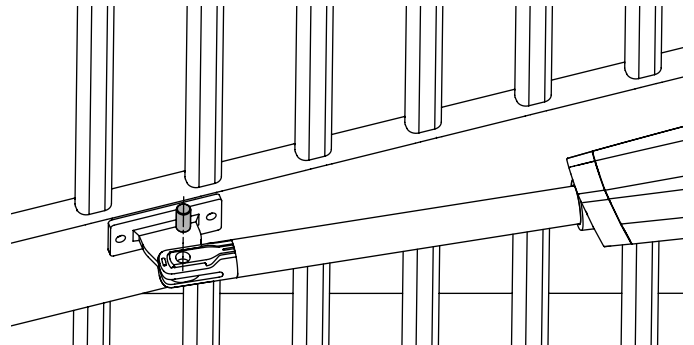

Insert the MPE1224 pin as indicated.
Perform an opening and closing operation.

Picture 21

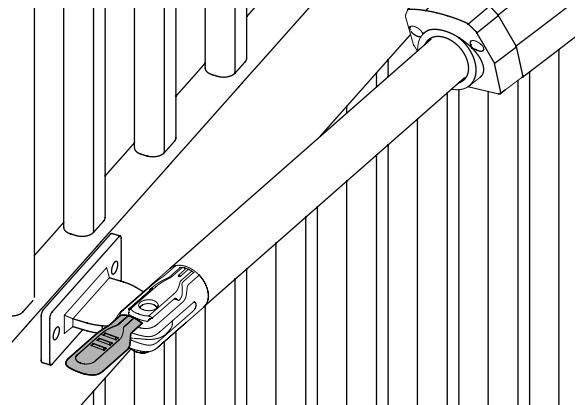

Insert the MTP28 fork cap and set the automation to 'locked' mode”.

6 ELECTRICAL WIRINGS

- All connections must be made without power. Switch the power OFF.
- Fit a device (e.g. thermomagnetic switch) that cuts electrically the system from the main power supply. The standards require a contact separation of at least 3 mm for each pole (EN 60335-1).
- Installation requires electrical and mechanical skills; must be carried out only by qualified personnel able to provide declaration of conformity type A on the whole installation (Machinery Directive 2006/42/EEC, Annex IIA).
- The main electrical circuit must also comply with current regulations and be carried out state of the art.
- The power lines to the motors, control unit and accessories must be separated to avoid interferences that could cause malfunction of the system.
- The power cable wired to the motor terminal has to make a wide downward bend to avoid the backflow of water inside the motor itself.

Picture 22

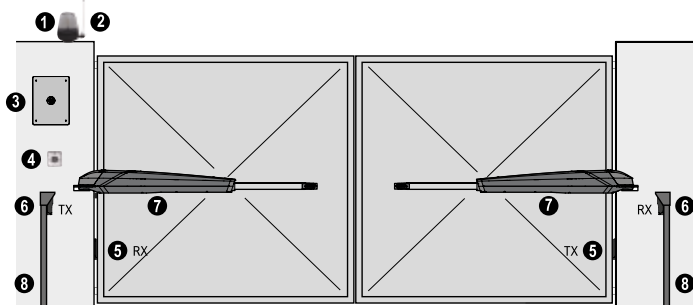

- 1_Flashing light 2_Antenna 3_Control unit 4_Key switch 5_CLOSING photocell 6_OPENING photocell 7_Motors 8_Photocell pillar

NB: Cables necessary for the installation of the system (not included) may vary according to the quantity and type of accessories and devices fitted.

6.1 POWER CABLE FEATURES CONNECTING THE CONTROL UNIT AND THE TERMINAL BLOCK ONBOARD THE MOTOR

Picture 23

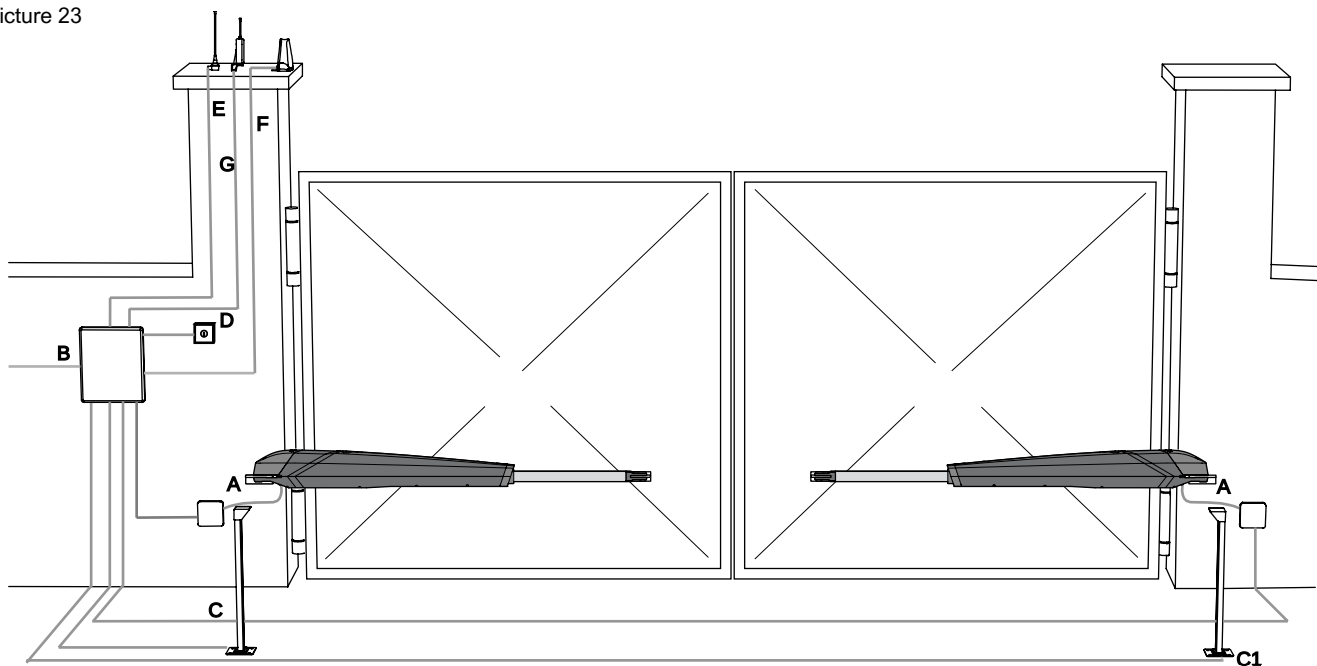

Power supply from control unit to motor terminal

	version 230V/115V	version 24V
B Control unit	2 x 1,5 mm ² + Terra	2 x 1 mm ² + Terra
C Photocell RX	4 x 0,5 mm ²	4 x 0,5 mm ²
G Photocell TX	2 x 0,5 mm ²	2 x 0,5 mm ²
D Key switch	2 x 0,5 mm ²	2 x 0,5 mm ²
E Antenna	RG58	RG58
F Flashing light	2 x 0,5 mm ²	2 x 0,5 mm ²
G Radio receiver	2 x 0,5 mm ²	2 x 0,5 mm ²

A Cable type:

- For power supply **230V** and outdoor use, choose cable type H05RN-F complying with 60245 IEC 57 (IEC); for indoor use, choose cable type H05VV-F complying with 60227 IEC 53 (IEC).
- For power supply up to **48V**, choose cable type FROR 20-22 II complying with EN 50267-2-1 (CEI).

Attention: maximum cable diameter 8 mm

For 230V type H05RN-F 4Gx0,75 mm²

For 24V type H05RN-F or FROR 20-22 2x1 mm²

Insert the cable through the cable gland.

Picture 24

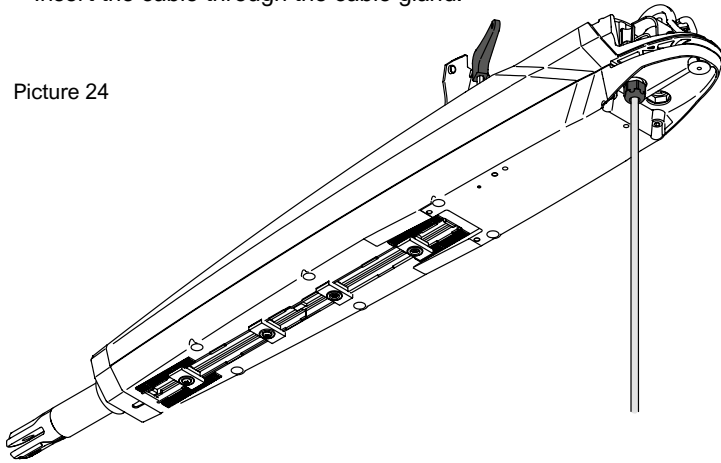

Picture 28

VERSION 24 V

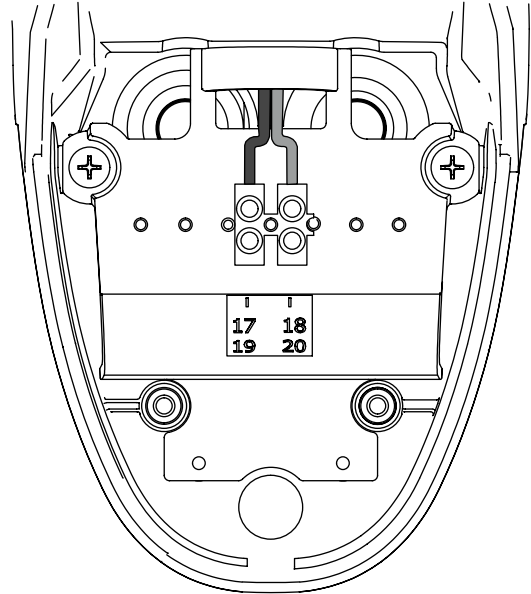

Picture 25

VERSION 230 V/115V

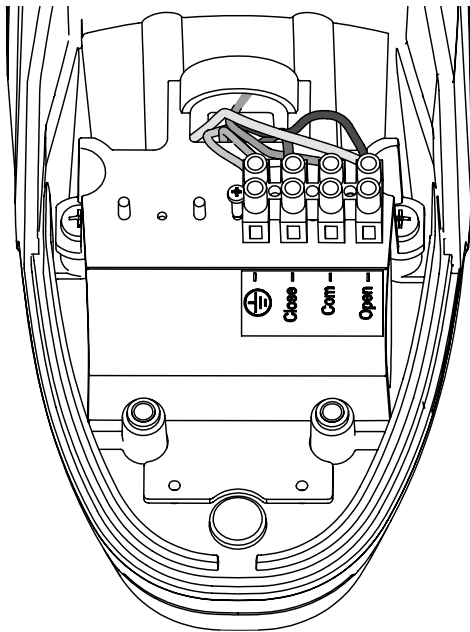

Picture 29

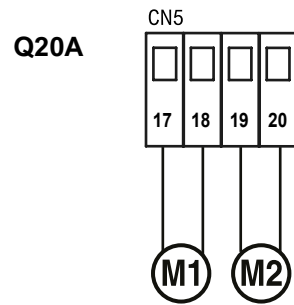

Wire the motor to the control unit respecting the correct terminals. Capacitors are prewired and stowed underneath the motor terminal compartment.

Picture 26

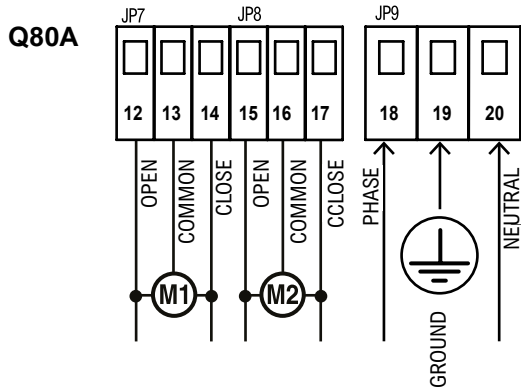

Picture 27

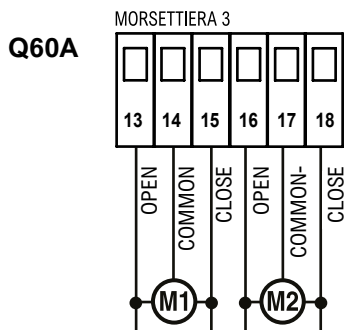

8 MAINTENANCE

ATTENTION!

Maintenance of the automation must be carried out by qualified technical personnel, in full compliance with the safety regulations established by current laws.

To keep the automation safety and in good operation over time, it is advisable to schedule a periodic maintenance plan and carry out the following inspections:

- Disconnect any electrical power source.
- Check the waste condition of all components that make up the automation.
- Check the gate bracket fixing screws and in case the mechanical limit switches.
- Check that screw connections are tightened properly.
- Unlock and check the correct manual operation in opening and closing.
- Put the gate to the closing position, lock the automation and carry out the programming procedure again, if necessary.

Checking the release system

- Check the efficiency of the release system: put the gate to closing position, unlock the system and make sure the release operation is smooth.
- Make sure the gate moves permanently free, clear of any friction points.

9 WARRANTY

PROTECO products are covered by a 3-year limited warranty from the manufacturing date stuck on the product.

In this period, Proteco Srl responds for malfunction due to construction faults, faulty parts or faulty assembly.

The guarantee is liable only if use, maintenance and instructions have been duly complied.

This warranty does not respond if fake spare parts are used or if fault is due to incorrect installation or force majeure conditions. Installation and maintenance are entirely at the installer care and responsibility.

Under no circumstances and in no way Proteco Srl will be liable for damages, loss of profits, savings or other accidental or indirect damages, deriving from the use or from the inability to use PROTECO products.

Any return without a return authorization number will be rejected.

Shipping of the returned product and related costs are responsibility of the buyer.

All defective products must be returned together with proof of purchase to:

PROTECO Srl Via Neive 77, 12050 Castagnito (CN) - Italia.

Warranty is void when:

- The product has been handled/stored under improper conditions of use and maintenance.
- The product has been repaired, modified or altered.
- The product has been subjected to misuse, negligence, electrical problems, storage in improper packaging, accident or natural events.
- The product was installed improperly.
- The product warranty label is illegible or completely missing.
- The malfunction is due to improper installation or natural and/or accidental causes (e.g. falls, oxidation, overvoltage).

When returning a product, remember to include in addition all your data (name, surname, address, telephone number and/or e-mail) to allow us to contact you and update you on your return procedure.

10 DISPOSAL

DISPOSAL OF THE SYSTEM

Any part of the system, including devices such as remote controls, must be disposed in compliance with current legislation, as they may be harmful for the environment.

Most of the materials used are similar to solid urban waste and can be handled accordingly.

They can be recycled through separate collection and disposed in authorized centers.

Other components (electronic boards, batteries, etc.) may instead contain polluting substances.

They must therefore be removed and delivered to companies authorized for their recovery and disposal.

Before proceeding, it is always advisable to check the specific regulations in force.

DISPOSAL OF PACKING

Packaging components (cardboard, plastics, etc.) are similar to solid urban waste and can be handled accordingly without any difficulty, simply by carrying out separate collection for recycling.

Before proceeding, it is always advisable to check the specific regulations in force.

COMPLIANCE DECLARATION

The Manufacturer: **PROTECO S.r.l.**
Address: Via Neive, 77 - 12050 CASTAGNITO (CN) - ITALY

declares that

The product type: Automation for swing gates and according accessories **RHINO XL**
model: **RHINO XL**

Is built to be integrated into a machine or to be assembled with other machinery to create a machine under provisions of 2006/42/EC Machinery Directive.

It complies with the essential requirements of EEC Directives:

2011/65/CE (RoHS 2) + 2015/863/UE (RoHS 3)
2014/35/UE (LVD) Low voltage Directive
2014/30/UE (EMC) Electromagnetic compatibility Directive

The product also complies with:

EN12453,
EN55014-1, EN55014-2,
EN61000-6-1, EN61000-6-3 EN 60335-1,
EN 60335-2-103

The manufacturer declares that the start-up of the machinery is not permitted unless the machine, in which the product is incorporated or of which is becoming a component, has been identified and declared as conformed to 2006/42/EC Machinery Directive.

Note: These products were tested in a typical homogeneous configuration

Castagnito, 14th July 2025

Marco Gallo
CEO

