

LEADER

Gearmotor for swing gates

Index

1.	SAFETY INSTRUCTIONS	<i>pag. 01</i>
	COMPLIANCE DECLARATION	<i>pag. 01</i>
2.	DESCRIPTION AND INTENDED USE	<i>pag. 01</i>
2.1	Technical data	<i>pag. 02</i>
2.2	Kit content	<i>pag. 02</i>
2.3	Dimensions	<i>pag. 02</i>
3.	INSTALLATION	<i>pag. 03</i>
3.1	Preliminary checks	<i>pag. 03</i>
3.2	Wiring	<i>pag. 03</i>
	3.2.1 Standard installation	
	3.2.2 Cable types and minimum thicknesses	
3.3	Establishing RH and LH operator	<i>pag. 04</i>
3.4	Fastening the gearmotor	<i>pag. 04</i>
	3.4.1 Vertical positioning quota	
	3.4.2 Horizontal positioning quota	
	3.4.3 Outward opening	<i>pag. 06</i>
3.5	Fastening rear bracket T1	<i>pag. 06</i>
3.6	Fastening front bracket S3	<i>pag. 06</i>
4.	RELEASING THE GEARMOTOR	<i>pag. 07</i>
5.	MAINTENANCE	<i>pag. 07</i>
6.	DISMANTLING AND DISPOSAL	<i>pag. 07</i>

1. SAFETY INSTRUCTIONS

Warning: Important safety instructions for people, READ CAREFULLY when you see this symbol: 
This product must only be used for its intended purpose. Any other use is dangerous.
Follow all instructions as improper installation may result in serious bodily injury.
Keep these warnings together with the installation and operation manuals that come with the gearmotor.



Always cut off the power supply before performing any type of intervention.



Always make sure the gearmotor is properly connected to the earth

Use and installation of the product must comply with Machinery Directive 2006/42/CE.
Verify that the system is EN 124445 and EN 12453 standard compliant.

Installation must be carried out by expert qualified personnel who knows the potential hazards associated and in full compliance with current regulations.
Use of the product must be restricted to its intended use. Any other use is to be considered dangerous and therefore forbidden.



**Do not allow children to play with the fixed command devices, or in the gate's area of operation.
Keep any remote control devices (i.e. transmitters) away from children,
to prevent the gearmotor from being accidentally activated**

Keep the gate and the gate opener regularly maintained. Use only Proteco's original spares.
Users are strictly forbidden to carry out any changes on the gate operator.
Proteco Cancelli Automatici Srl is not liable for any damage resulting from improper, wrongful or unreasonable use.

CE COMPLIANCE DECLARATION

Manufacturer: PROTECO S.r.l.
Address: Via Neive, 77 – 12050 Castagnito (CN) – ITALIA
declares that
The product type: LEADER electromechanical gear motor for swing gates
Models: LEADER 3 TI, LEADER 4 TI, LEADER 5 TI, LEADER 24 3 TI, LEADER 24 4 TI, LEADER 24 5 TI
LEADER 3 TA, LEADER 24 4 TA

Is built to be integrated into a machine or to be assembled with other machinery to create a machine under provisions of 2006/42/EC Machinery Directive, with reference in particular to the following requirements: 1.1.2 1.1.3 1.1.5 1.2.1 1.2.2 1.2.3 1.2.6 1.3.2 1.3.4 1.3.9 1.4.1 1.4.2.1 1.5.1 1.5.4 1.5.6 1.5.8 1.5.13 1.6.1 1.6.4 1.7.1 1.7.3 1.7.4

It complies with the essential requirements of EEC Directives:

2004/108/CE (electromagnetic compatibility)
1999/5/CE (R&TTE)
2011/65/CE (directive on the restriction of the use of certain hazardous substances in electrical and electronic equipment)

It complies with the essential requirements of EEC Directives:

EN 12453 Industrial, commercial and garage doors and gates. Safety in use of power operated doors. Requirements
EN 12445 Industrial, commercial and garage doors and gates. Safety in use of power operated doors. Test methods.
EN 60335-1 Safety of household and similar electrical appliances - Part 1: General requirements
EN 60335-2-103 Household and similar electrical appliances - Part 2-103: Particular requirements for drives for gates, doors and windows.

The manufacturer also declares that the start-up of the machinery is not permitted unless the machine, in which the product is incorporated or of which is becoming a component, has been identified and declared as conformed to 2006/42/EC Machinery Directive.

Castagnito, 3rd October 2016

Marco Gallo
CEO

2. DESCRIPTION AND INTENDED USE

The LEADER operator range is designed to automate swing gates for residential use.
The use of this product for purposes other than those described above and installation executed in a manner other than as instructed in this technical manual are prohibited.
All LEADER systems are irreversible, therefore no electric-lock is needed.
In case of power cut the gate operator can be easily released by manual operation.
The 24V LEADER systems can be connected to a back-up battery to grant a full operation cycle in case of power cut.

LEADER TI

	Leader 3	Leader 4	Leader 5	Leader 3 24	Leader 4 24	Leader 5 24	Leader 3 115	Leader 4 115	Leader 5 115
Motor power supply	230V ~ 50Hz	230V ~ 50Hz	230V ~ 50Hz	24V dc	24V dc	24V dc	115V ~ 60Hz	115V ~ 60Hz	115V ~ 60 Hz
Max draw.	1,2 - 1,7A	1,2 - 2A	1,2 - 1,7A	0,5 - 0,75A	0,5 - 0,75A	0,5 - 0,75A	2,0 - 2,3A	2,0 - 2,3A	2,0 - 2,3A
Power	280W	280W	280W	50W	50W	50W	300W	300W	300W
Capacitor	8µF	8µF	8µF	—	—	—	30µF	30µF	30µF
Thermal protection	150°C	150°C	150°C	—	—	—	150°C	150°C	150°C
Adjustable thrust	2800 N	2800 N	2800 N	2500 N	2500 N	2500 N	3000 N	3000 N	3000 N
Protection rating	44	44	44	44	44	44	44	44	44
Revolutions	1400 rpm	1400 rpm	1400 rpm	1600 rpm	1600 rpm	1600 rpm	1700 rpm	1700 rpm	1700 rpm
Opening angle	110° deg	110° deg	110° deg	110° deg	110° deg	110° deg	110° deg	110° deg	110° deg
Opening time (90°)	17"	22"	27"	15"	20"	25"	14"	18"	22"
Leaf weight	350 Kg	350 Kg	250 Kg	275 Kg	250 Kg	150 Kg	300 Kg	250 kg	200 kg
Leaf length	2 m	2,75 m	3,5 m	2,0 m	2,5 m	3,0 m	2,0 m	2,75 m	3,50 m
Duty cycle	40%	40%	40%	80%	80%	80%	40%	40%	40%

LEADER TA

	Leader 4 TA	Leader 4 TA 24	Leader 4 TA 115
Motor power supply	230V ~ 50Hz	24V dc	115V ~ 60Hz
Max draw.	1,2 - 1,7A	0,5 - 0,75A	2,0 - 2,3A
Power	280W	50W	300W
Capacitor	8µF	—	30µF
Thermal protection	150°C	—	150°C
Adjustable thrust	2800 N	2500 N	3000 N
Protection rating	44	44	44
Revolutions	1400 rpm	1600 rpm	1700 rpm
Opening angle	110° deg	110° deg	110° deg
Opening time (90°)	22"	20"	18"
Leaf weight	300 Kg	200 Kg	200 Kg
Leaf length	2,75 m	2,5 m	2,75 m
Duty cycle	40%	80%	40%

2.2 KIT CONTENT

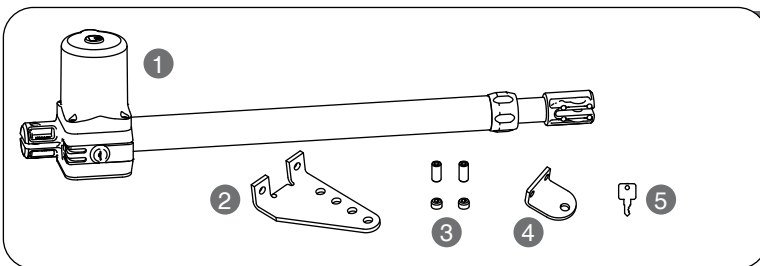

LEADER TI

1	LEADER Swing operator
2	SPIP0770 Rear RH bracket T1
	SPIP0870 Rear LH bracket T1
3	MGR1410Z Fixing pack
	MPE1226
4	SPIA0270 Front bracket S3
5	Release key

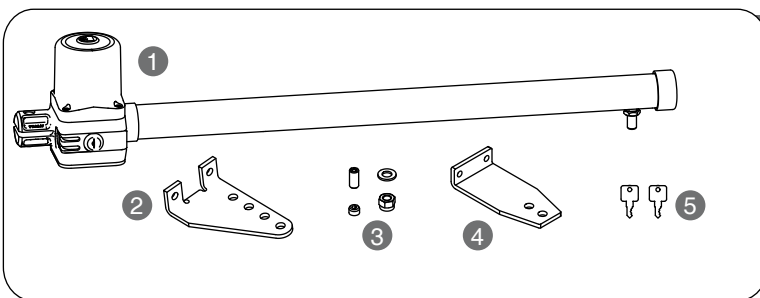

LEADER TA

1	LEADER Swing operator
2	SPIP0770 Rear RH bracket T1
	SPIP0870 Rear LH bracket T1
3	MGR1410Z Fixing pack
	MPE1226
	MRO12Z
	MDAM12AB
4	SPIA0370 Front bracket S4
5	Release key

2.3 DIMENSIONS

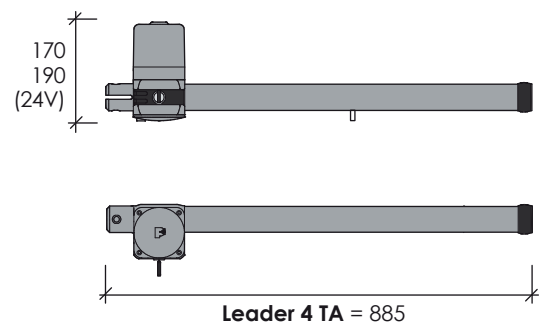
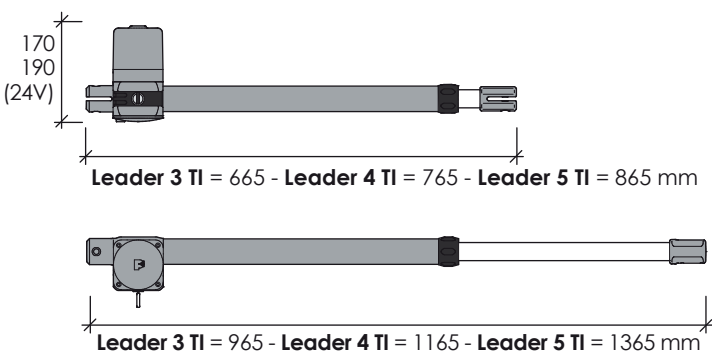

3. INSTALLATION

3.1 Preliminary checks

Before installing make sure:

- The gate conditions are suitable to automate.
- Weight, dimensions and gate construction are proper for the operator you intend to buy.
- You have suitable mechanical ground stops.
- The automated parts are in good mechanical conditions.
- The opening of the automated gate is not an entrapment hazard as regards any surrounding fixed parts and there is sufficient space for manual release.
- Any lawn watering devices will not wet the gearmotor from the bottom up.
- The earth cable is properly connected.
- Do not install onto gates on either an upward or downward slope (i.e. that are not on flat, level ground).

3.2 Wiring

3.2.1 Standard installation

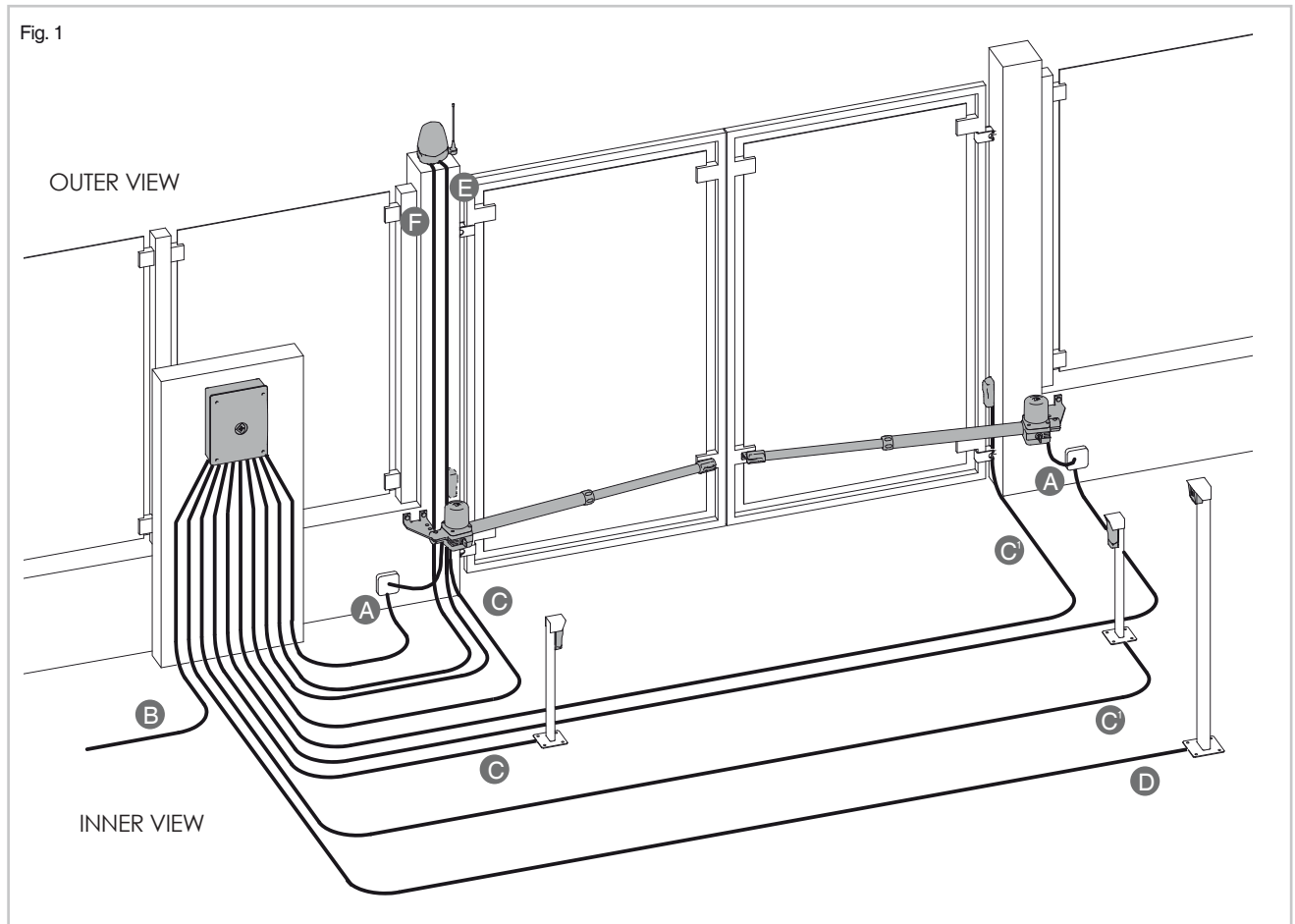

3.2.2 CABLE TYPES AND MINIMUM THICKNESSES

The quantities of tubes and cables needed (not included in the kit) depend on the type and number of accessories connected to the gate area.

	230V	24V
A operator	3x1,5 Earth	2x1,5
B Control panel	2x1,5 + Earth	2x1,5 + Earth
C Photocell receiver	rx 4x0,75	rx 4x0,75
C' Photocell transmitter	tx 2x0,75	tx 2x0,75
D Key switch	2x0,75	2x0,75
E Aerial	RG58	RG58
F Blinker	2x0,75	2x0,75

- Cut off the power before starting wiring.
- Make sure you have set up a suitable dual-pole cut off device (3 mm wires) along the power supply.
- Make sure you have suitable tubing and conduits for the electrical cables: connect the motors, control panel and accessories using separated corrugated tubes, in order to prevent interferences that may result in bad operation.
- Fit the power cable keeping a curve as shown in picture 2, in order to avoid water backflow inside the operator.
- All opening commands and safety devices must be free of tension (dry contact).

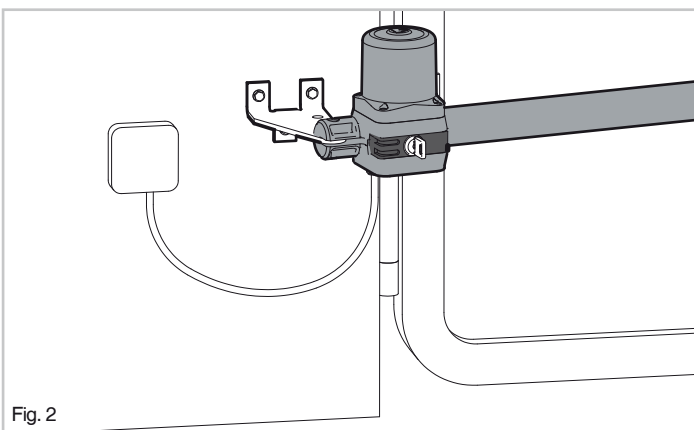

Fig. 2

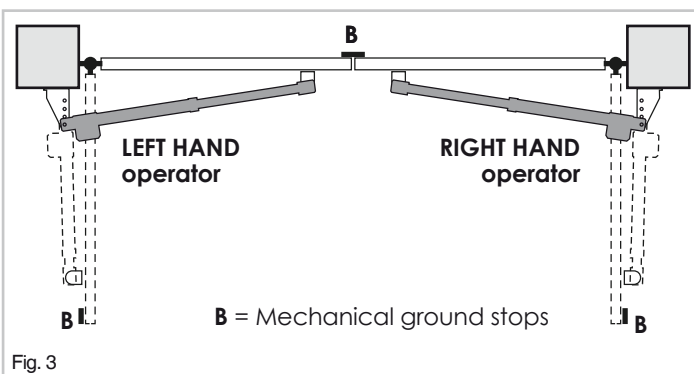

Fig. 3

3.3 ESTABLISHING RH AND LH OPERATOR

A RH motor and a **LH motor** are supplied with the kit. Ensure you are mounting the correct handed motor to the leaf (see picture 3, inner view).

Make sure there are mechanical ground stops in opening and closing (see picture **B**).

LEADER TI

Gate in closing position - inox pipe maximum extension:

Leader 3 = 345 mm

Leader 4 = 445 mm

Leader 5 = 545 mm

Gate in opening position - inox pipe minimum extension 50 mm (see picture 4).

LEADER TA

Gate in closing position: minimum distance 50 mm.

Gate in opening position: maximum distance 450 mm. (see picture 5).

Fig. 4

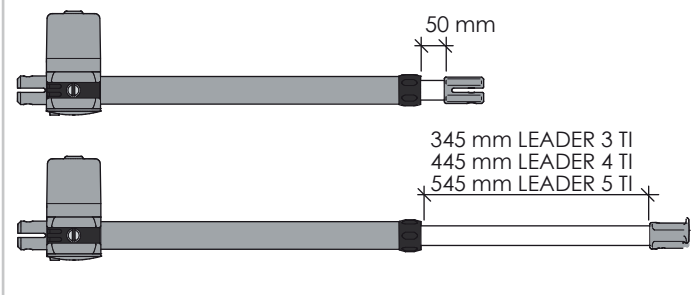
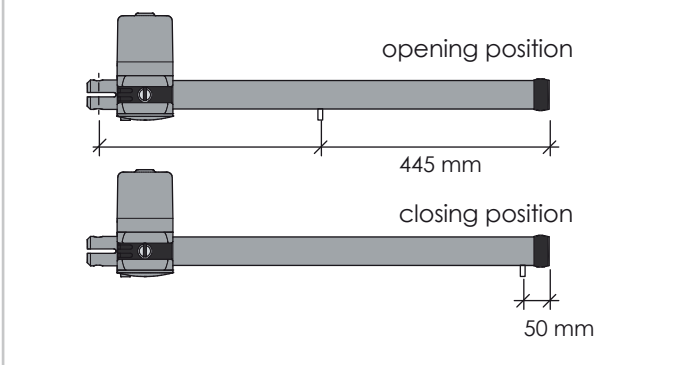

Fig. 5



3.4 FASTENING THE GEARMOTOR

3.4.1 Vertical positioning quota

- If the gate is sturdy you can fit the gearmotor wherever it goes, at any height from ground.
- If the gate is particularly light fit the gearmotor as close as possible to gate centerline.

3.4.2 Horizontal positioning quota

Gate leaf hinged in the center of the pillar (see picture 6).

Gate leaf hinged on the corner of the pillar (see picture 7).

Best of performance is obtained respecting **A** and **B** dimensions, see picture 8 (opening angle 90°).

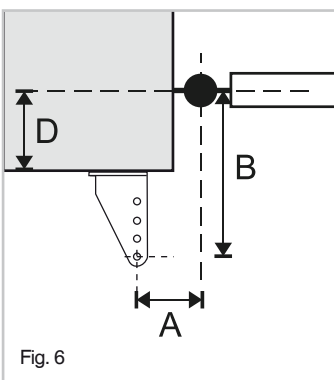

Fig. 6

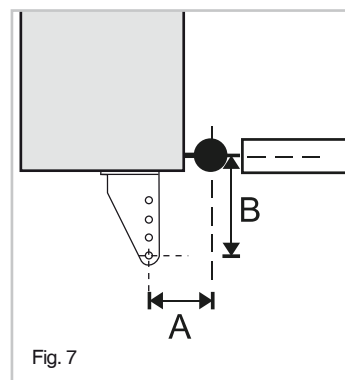
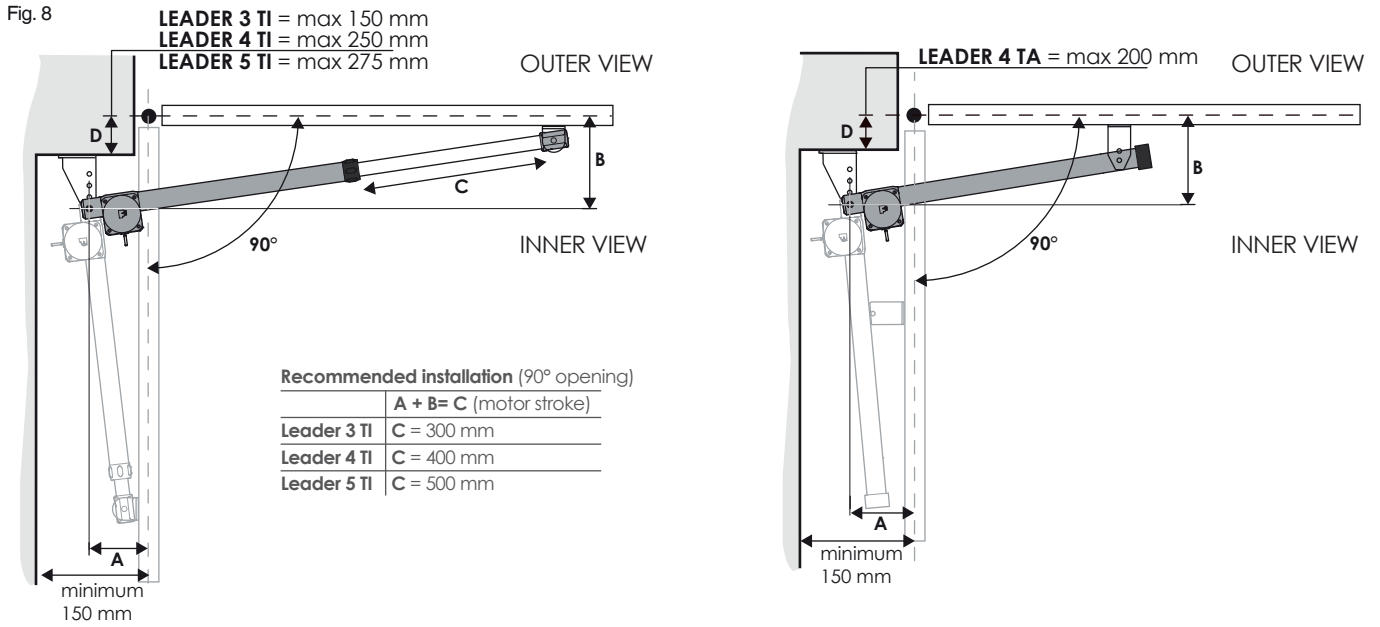

Fig. 7



If the ideal scenario of **A** and **B** is not applicable, refer to the below table to determine the brackets position (values are expressed in **mm**).

Tab. 1

LEADER 5 TI

D	225	200	175	150	125	100	75	50	25
A	225	250	245	240	235	260	285	310	335
B	275	250	255	260	265	240	215	190	165
Rear bracket	50	50	80	110	140	140	140	140	140
Minimum leaf length	1150	1130	1130	1130	1140	1120	1100	1070	1050

LEADER 4 TI

D	200	175	150	125	100	75	50	25	0
A	150	175	200	195	190	185	210	235	260
B	250	225	200	205	210	215	190	165	140
Rear bracket	50	50	50	80	110	140	140	140	140
Minimum leaf length	1030	1000	980	990	990	970	970	950	930

LEADER 3 TI

D	150	125	100	75	50	25	0
A	100	125	150	145	140	135	160
B	200	175	150	155	160	165	140
Rear bracket	50	50	50	80	110	140	140
Minimum leaf length	880	860	840	840	850	850	830

LEADER 4 TA

D	200	175	150	125	100	75	50	25	0
A	150	175	200	195	190	185	210	235	260
B	250	225	200	205	210	215	190	165	140
Rear bracket	50	50	50	80	110	140	140	140	140
Minimum leaf length	1030	1000	980	990	990	970	970	950	930

3.4.3 OUTWARD OPENING

Your gate can be automated for opening outwards too. In this case the value of **A** dimension shall be calculated towards the gate center. See picture 9 and 10 and fit the bracket accordingly.

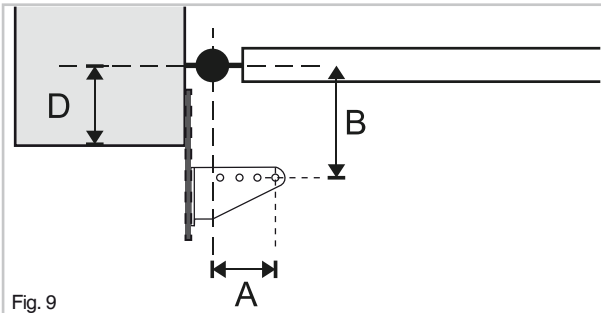
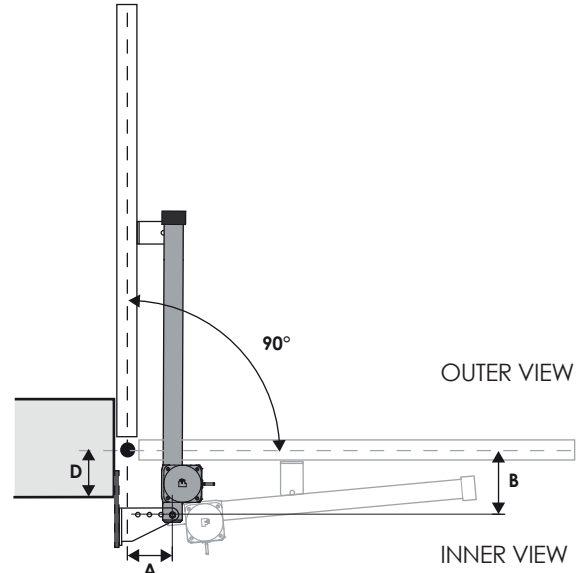
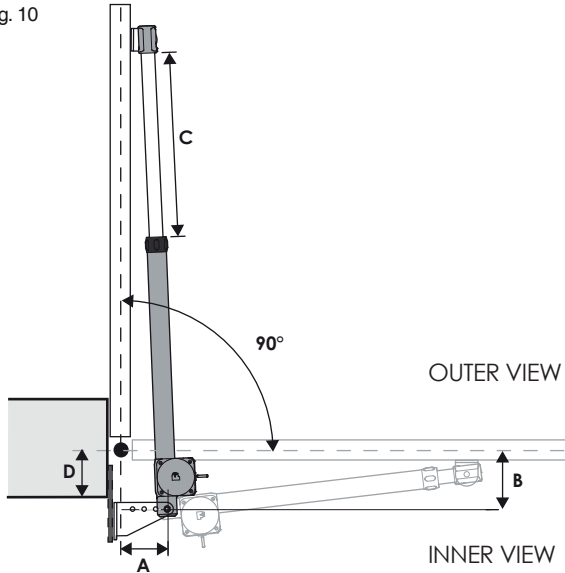

Fig. 9

Fig. 10



3.5 FASTENING REAR BRACKET T1

Weld or bolt the rear **bracket T1** on the post, applying the **A** and **B** quota calculated according to the gate hinge position and the motor rotation point. Chemical bolts can be used and must comply with the post features (brick, wood, steel, etc. etc.). When fixing keep a minimum distance of 30/35 mm from the post edge in order to avoid damages (see picture 11).

- Rear **brackets T1** are provided **LH** and **RH**, to match to the according LH and RH motor (see picture 12).
- When fixing the operator to the rear **bracket T1**, plug **PR1** rotation pin downward oriented (see picture 13).

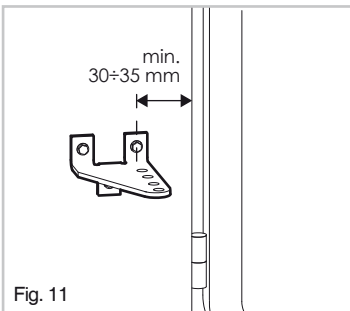

Fig. 11

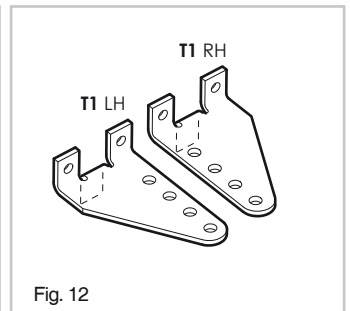

Fig. 12

3.6 FASTENING FRONT BRACKET S3

3.6.1 LEADER T1

To determine the position of **bracket S3**:

- Put the gate in closing position.
- Release the gearmotor.
- Extend the inox pipe arm fully.
- Turn back the arm 2 cms. This avoids the motor to "leap forward" (see picture 14)
- Affix the **bracket S3** to the motor slot. Plug the rotation pin **PR1** into the locating hole.
- Fit the **bracket S3** on the gate.
- Keep the motor horizontal, fix or weld.

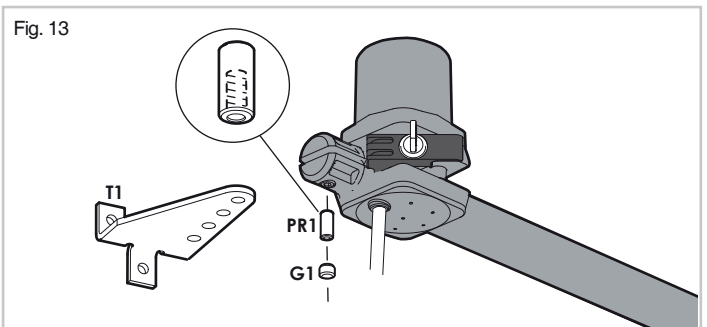

Fig. 13

⚠ Check the manual opening of the leaf before definitively fixing the bracket to make sure the gate can open fully to your required angle.

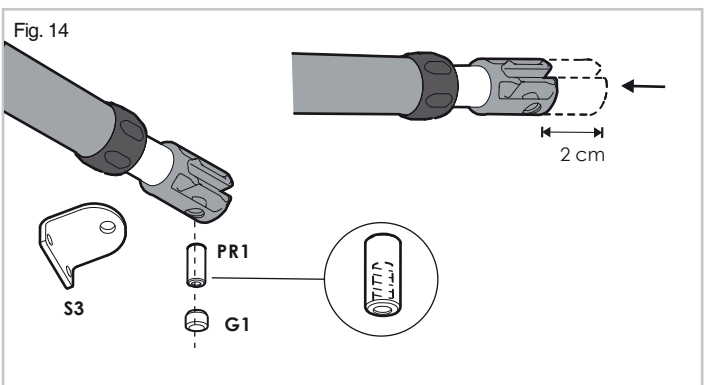

Fig. 14

3.6.2 LEADER TA

To determine the position of **bracket S4**:

- Put the gate in closing position
- Release the gearmotor
- Slide the front drive pin to the closing limit-switch point (keep a distance of 45 mm between the pin and the pipe end terminal (see picture 15)).
- Fix the **bracket S4** to the drive pin. See picture 16.
- Fit the **bracket S4** onto the gate and keep the motor horizontal. Fix or weld.



Check the manual opening of the leaf before definitively fixing the bracket to make sure the gate can open fully to your required angle.

Fig. 15

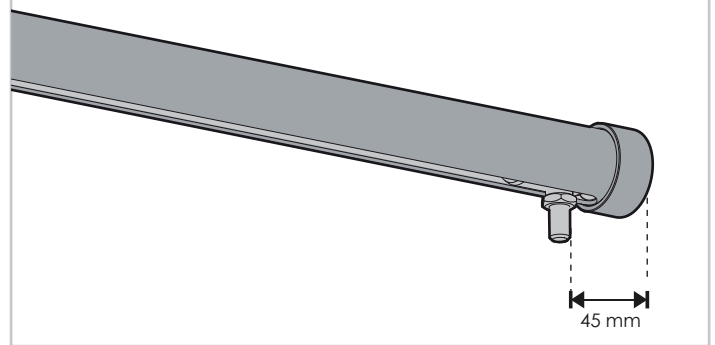
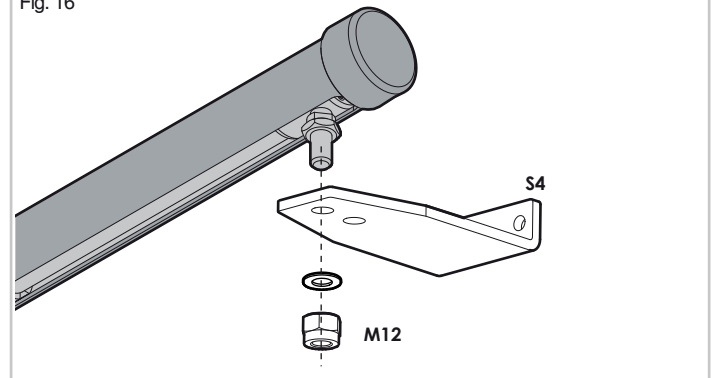

Fig. 16



4. RELEASING THE GEARMOTOR

LH OPERATOR

- Insert the key and turn 90° clockwise (picture 17).
- Pull the release handle outwards to unlock the motor.
- Turn the key 90° clockwise to keep the handle locked.
- Now you can proceed to manual operation.
- To return to automatic operation invert the procedure.

RH OPERATOR

- Insert the key and turn 90° counterclockwise (picture 17).
- Pull the release handle outwards to unlock the motor.
- Turn the key 90° counterclockwise to keep the handle locked.
- Now you can proceed to manual operation.
- To return to automatic operation invert the procedure.



The gate can be locked in any position after the first start command the system will return to its default settings.

Fig. 17

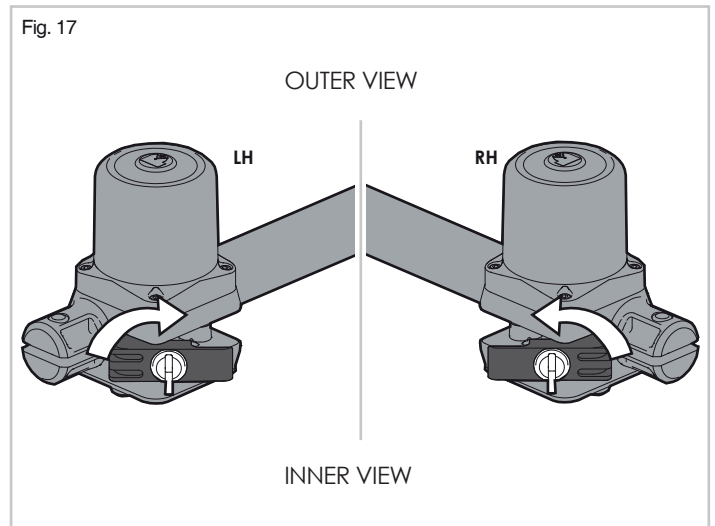

5. MAINTENANCE

Functional checks must be performed once every 6 months, including: checking the state of lubrication and tightness of the anchoring screws on the operator as well as the good operation of all safety devices.

6. DISMANTLING AND DISPOSAL



DO NOT DISPOSE OF IN NATURE!

Some components may contain hazardous waste. They must, thus, be removed and turned into licensed firms for their disposal. Before acting always check the local laws on the matter.

LEADER TI

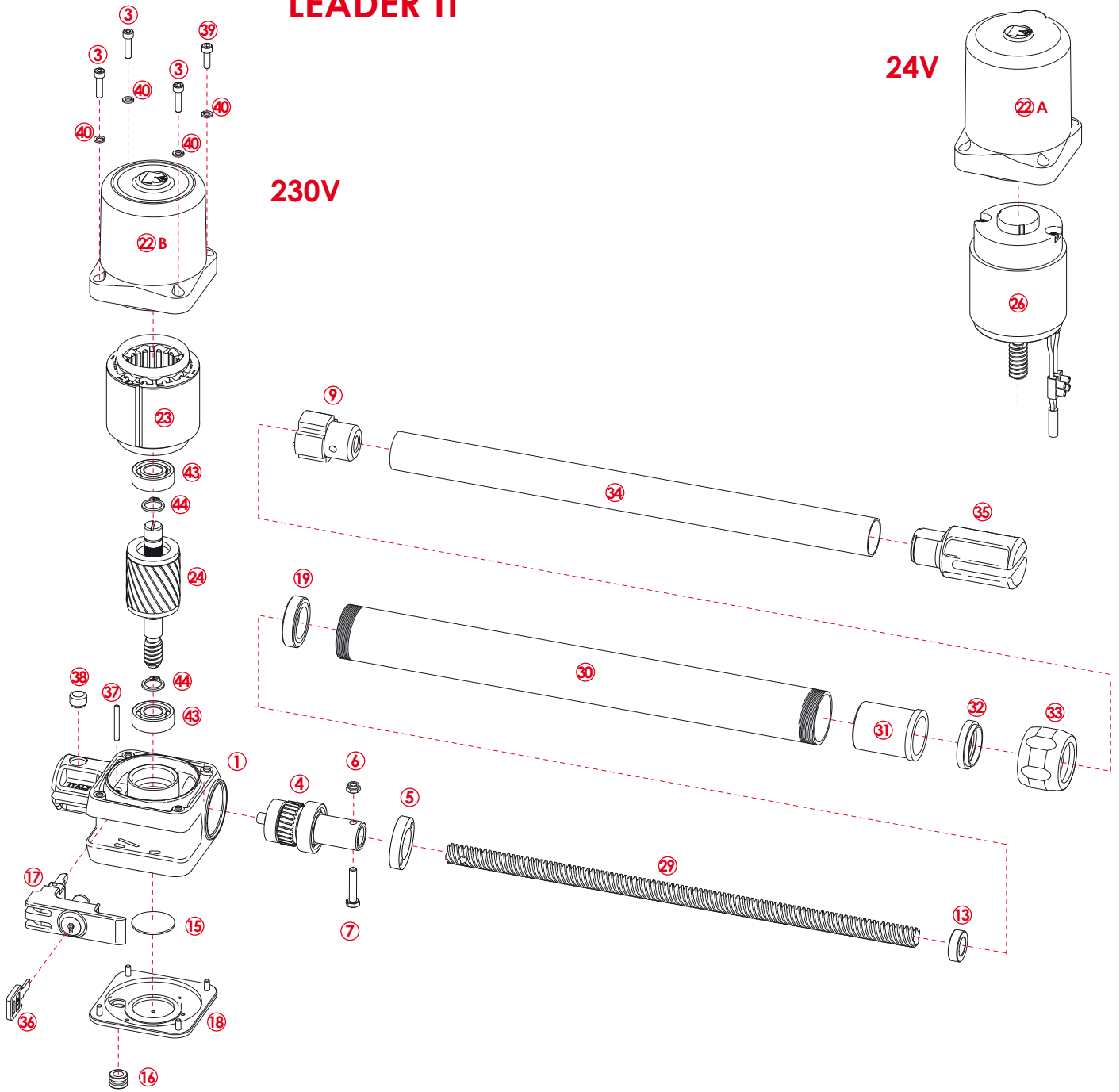

LEADER TA

